

## INSIDE YOUR HOLLEY CARBURETOR

The carburetor is quite simply a fuel metering device that operates under the logical and straightforward laws of physics. It has evolved over the years from a very simple and basic design to the complex and intricate models that are available today. A carburetor's functions can be easily analyzed and understood but at the same time it can be frustratingly difficult to troubleshoot problems associated with it. Many times a carburetor is looked at as the prime culprit or the main cause for a myriad of other engine-related difficulties that might exist. Therefore, it's best to check and verify the condition of the complete engine system before proceeding with any carburetor work.

There should be no vacuum leaks, the carburetor floats and the ignition timing should be properly set and the carburetor and engine should both be in sound mechanical condition. There's an old saying that "You can't beat a dead horse". Well, the same can be said about carburetors. Tuning the carburetor won't cure bad valves, leaky head gaskets, worn piston rings or cracked and leaking vacuum lines and, no matter how much time and effort you devote toward it, the results will be the same.

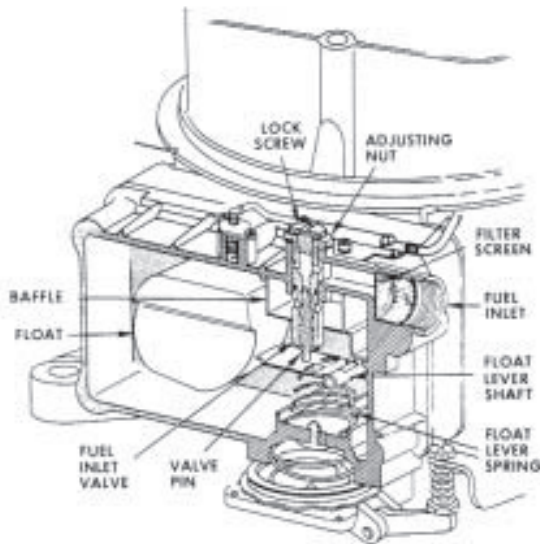

**Fuel Inlet System. Side Pivot/ Hung Float  
Externally Adjustable Fuel Inlet Valve.**

## FUEL INLET SYSTEM

The fuel inlet system consists of a fuel bowl, fuel inlet fitting, fuel inlet needle and seat and a float assembly. A fuel inlet screen or filter is usually installed in the fuel inlet fitting. However, if there is no filter or screen in the fuel inlet fitting, an in-line filter must be installed to prevent dirt or other contaminants from entering the carburetor.

Holley performance carburetors are equipped with a fuel bowl that is designed either for a center pivot or a side pivot float. An externally adjustable needle and seat assembly is used so that the float level can be easily adjusted without the need to disassemble the carburetor.

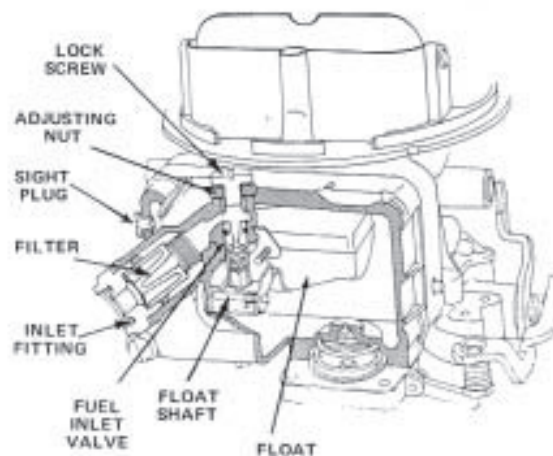

**Fuel Inlet System. Center Pivot/ Hung Float  
Externally Adjustable Fuel Inlet Valve.**

## IDLE SYSTEM

The idle system supplies the air/fuel mixture to operate the engine at idle and low speeds. Fuel enters the main well through the main metering jet that is screwed into the metering block. Some of this fuel is then bled off to an idle well where it is mixed with air from the idle air bleed hole. The idle well leads directly to the idle discharge port and the idle transfer system where this air/fuel mixture is discharged.

Most Holley Street Performance, O.E. Muscle Car, Competition and Pro-Series HP carburetors utilize idle mixture screws, located on the sides of the primary metering block. These control the volume of the pre-mixed air/fuel coming through the idle well. Turning the screws clockwise will "lean" the idle system. Conversely, turning the screws counterclockwise will "richen" the idle system.

The initial adjustment is made by turning the mixture screws in a clockwise direction until they lightly bottom. Back them both off 1-1/2 turns. Connect a vacuum gauge to a carburetor vacuum port that will have access to full manifold vacuum at idle. Start the engine and allow it to warm up. Once the engine has warmed up and the idle stabilized, the choke should be disengaged. Adjust the idle mixture screws to obtain the highest vacuum reading. Each screw should be turned an equal amount so that the system is balanced.

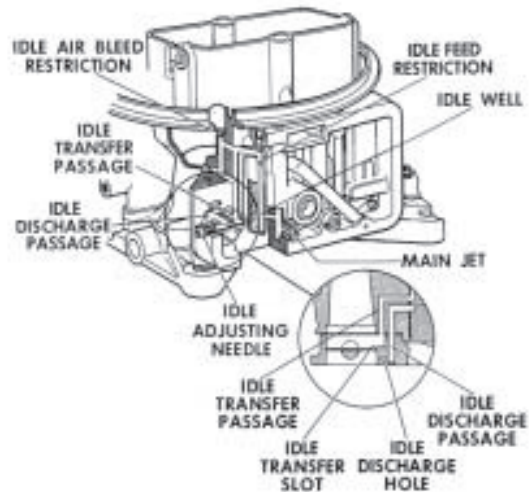

**Idle System.**  
**Model 2300 — Primary Side 4V.**

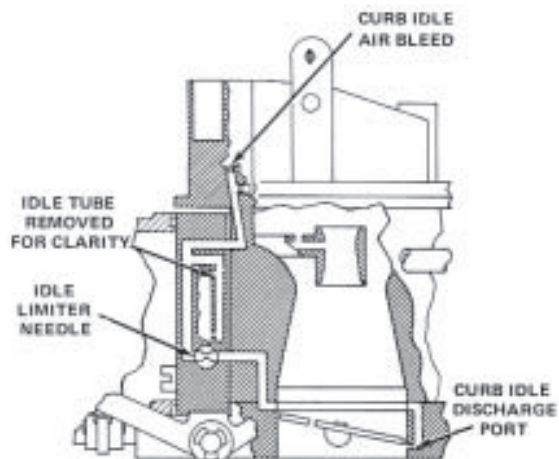
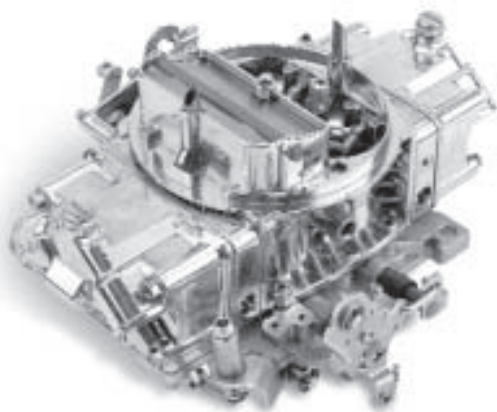

**Curb Idle System.**  
**Primary Idle Transfer System.**

## MAIN METERING SYSTEM

The main metering system is designed to supply the leanest fuel mixture for cruising in the 35 MPH and over range. Operation is simple. Fuel from the main metering jet enters the main well and is mixed with air from the high speed air bleed. Engine vacuum pulls this air/fuel mixture and discharges it through the booster venturi and into the manifold through the throttle bores.

On a street vehicle optimum jetting can be determined by driving at various steady speeds and taking vacuum and spark plug readings. Manifold vacuum will increase the closer you get to ideal jetting; it will fall off once you get past this point. The ideal color for the spark plug porcelain is light brown or tan. A color lighter than this indicates that the carburetor is jetted lean; a darker color indicates that the carburetor is jetted rich.

Holley jets are number-stamped on their side for identification purposes. A higher relative number indicates a larger jet size. Changing to a larger or smaller jet will either richen or make leaner the carburetor's fuel curve from part throttle to full throttle, respectively.

**NOTE:** Jump two sizes when changing the carburetor jetting. There is approximately a 4-1/2% flow difference from one jet size to the next and one size won't make that much of a difference. If you must go up or down 8-10 jet sizes then you have a problem either with the fuel delivery system or the carburetor is wrong for the application.

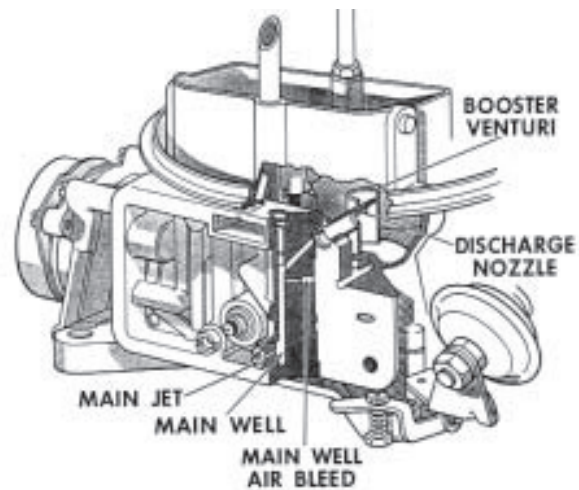

Main Metering System.

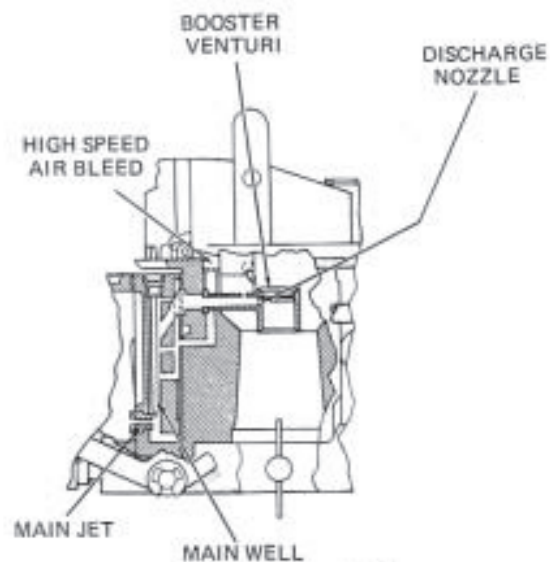

Side View Main Metering System.  
Showing Idle Tube in Main Well.

## ACCELERATOR PUMP SYSTEM

The accelerator pump system consists of three main components: the pump diaphragm, the pump cam and the pump nozzle. This is the carburetor system that is most responsible for having good, crisp, off-idle throttle response. Its purpose is to inject a certain amount of fuel down the throttle bores when the throttle is opened. By accomplishing this purpose it acts to smooth the transition between the idle and main circuits so that no stumble, hesitation or sluggishness will be evident during this transition phase.

The first adjustment to check is the clearance between the pump operating lever and the pump diaphragm cover's arm, at wide open throttle. This clearance should be around .015". The purpose for this clearance is to assure that the pump diaphragm is never stretched to its maximum limit at wide open throttle. This will cause premature pump failure. Once this clearance has been set take a good look at the pump linkage and work the throttle. Make sure that the accelerator pump arm is being activated the moment that the throttle begins to move. This will assure that pump response will be instantaneous to the movement of the throttle. These adjustments can be made by turning the accelerator pump adjusting screw that is located on the accelerator pump arm together with the pump override spring and lock nut.

The amount of fuel that can be delivered by one accelerator pump stroke is determined by the pump's capacity and the profile of the pump cam. The period of time that it will take for this pre-determined amount of fuel to be delivered is affected by the pump nozzle size.

A larger pump nozzle will allow this fuel to be delivered much sooner than a smaller pump nozzle. If you need more pump shot sooner, then a larger pump nozzle size is required. During acceleration tests, if you notice that the car first hesitates and then picks up, it's a sure bet that the pump nozzle size should be increased. A backfire (lean condition) on acceleration also calls for a step up in pump nozzle size. Conversely, if off-idle acceleration does not feel crisp or clean, then the pump nozzle size may already be too large. In this case a smaller size is required.

Holley accelerator pump nozzles are stamped with a number which indicates the drilled pump hole size. For example, a pump nozzle stamped "35" is drilled .035". Pump nozzle sizes are available from .025" to .052". Please note that whenever a .040" or larger accelerator pump nozzle is installed the "hollow" pump nozzle screw should also be used. This screw will allow more fuel to flow to the pump nozzle, assuring that the pump nozzle itself will be the limiting restriction in the accelerator pump fuel supply system.

Accelerator Pump System.

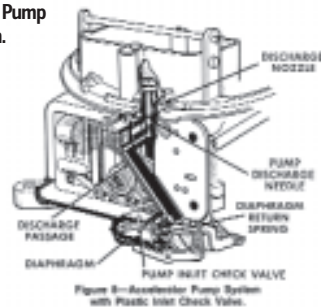

**NOTE:** When changing the pump nozzle it's best to jump three sizes. For example if there's currently an off-line hesitation with #28 (.028") pump nozzle, try a #31 (.031") pump nozzle. If you must use a #37 (.037") or larger pump nozzle, then also use a 50cc pump.

The same applies to the accelerator pump cams. Once a pump nozzle size selection has been made the accelerator pump system can be further tailored with the pump cam. Holley offers an assortment of different pump cams, each with uniquely different lift and duration profiles, that are available under Holley P/N 20-12. Switching cams will directly affect the movement of the accelerator pump lever and, subsequently, the amount of fuel available at the pump nozzle. Lay out the pump cams side by side and note the profile differences. This little exercise may help to better explain the differences between the cams and their effect on pump action.

Installing a pump cam is straightforward. It's a simple matter of loosening one screw, placing the new pump cam next to the throttle lever and tightening it up. There are two and sometimes three holes in each pump cam, numbered 1, 2 and 3. Placing the screw in position #1 activates the accelerator pump a little early, allowing full use of the pump's capacity. Generally, vehicles which normally run at lower idle speeds (600 or 700 RPM) find this position more useful because they can have a good pump shot available coming right off this relatively low idle. Positions #2 and #3 delay the pump action, relatively speaking. These two cam positions are good for engines that idle around 1000 RPM and above. Repositioning the cam in this way makes allowance for the extra throttle rotation required to maintain the relatively higher idle setting. Pump arm adjustment and clearance should be checked and verified each and every time the pump cam and/or pump cam position is changed.

Lastly, a 50cc accelerator pump conversion kit is available under Holley P/N 20-11 when maximum pump capacity is desired.

## POWER ENRICHMENT SYSTEM

The power enrichment system supplies additional fuel to the main system during heavy load or full power situations. Holley carburetors utilize a vacuum operated power enrichment system and a selection of power valves is available to "time" this system's operation to your specific needs. Each Holley power valve is stamped with a number to indicate the vacuum opening point. For example, the number "65" indicates that the power valve will open when the engine vacuum drops to 6.5" or below. An accurate vacuum gauge, such as Holley P/N 26-501, should be used when determining the correct power valve to use. A competition or race engine which has a long duration high overlap camshaft will have low manifold vacuum at idle speeds. If the vehicle has a manual transmission, take the vacuum reading with the engine thoroughly warmed up and at idle. If the vehicle is equipped with an automatic transmission, take the vacuum reading with the engine thoroughly warmed up and idling in gear. In either case, the power valve selected should have a vacuum opening point about 2" Hg below the intake manifold vacuum reading taken.

A stock engine, or one that is only mildly built for street use, will have high manifold vacuum at idle speeds. To determine the correct power valve the vehicle should be driven at various steady speeds and vacuum readings taken. The power valve selected should have an opening point about 2" Hg below the lowest steady speed engine vacuum observed.

Most of the popular Holley "Street Legal" and "Street Performance" carburetors incorporate a power valve blow-out protection system. A special check valve is located in the throttle body expressly for this purpose. This check valve is designed to be normally open but will quickly seat to close off the internal vacuum passage when a backfire occurs. Once closed, the check valve interrupts the pressure wave caused by the backfire, thus protecting the power valve.

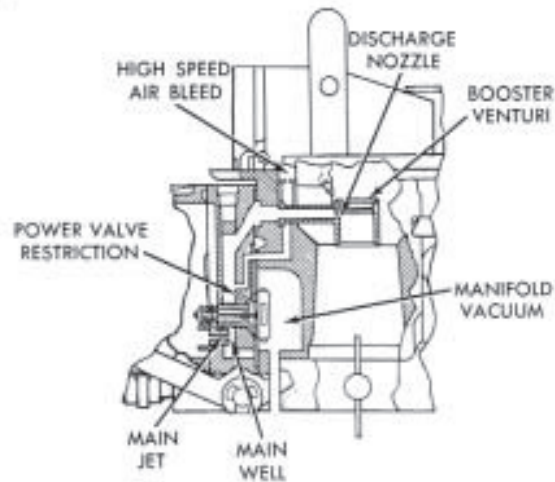

Power Enrichment System.

## THE TRUTH ABOUT POWER VALVES USED WITH HOLLEY CARBURETORS

There still seems to be a lot of misconception about Holley carburetors blowing power valves. Nothing could be further from the truth. Holley performance carburetors built since 1992 have utilized a power valve check system that effectively eliminated this infrequent problem. Consisting of a spring, brass seat and check ball, the check ball system is 100% effective protecting the power valve diaphragm from damage due to engine backfire.

The power valve check ball is designed to be normally open but quickly seals to close off the internal vacuum passage when a backfire occurs. Once closed, the check valve interrupts the pressure wave generated by the backfire, thus protecting the power valve diaphragm. There is no way that the power valve's diaphragm can rupture due to an engine backfire!



## CHOKE SYSTEM

The choke system is designed to supply a rich fuel mixture to the engine for cold starts and cold drive-away conditions.

Holley carburetors with chokes will come equipped with either a manual, electric or hot air choke. All Holley square flange carburetors originally equipped with either a manual or hot air choke can be converted to automatic electric choke operation with the proper kit. Conversely, those equipped with either an electric or hot air choke can be converted to manual choke operation with the proper kit.

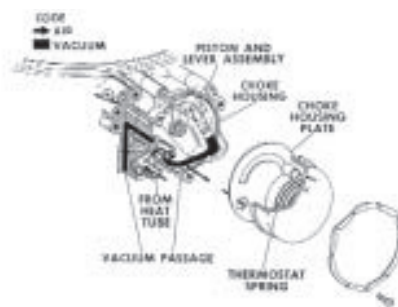

Integral Automatic Choke.

## SECONDARY SYSTEM

The secondary system of a Holley four barrel carburetor can be either vacuum or mechanically operated.

The opening rate of a mechanical secondary system is pre-determined by the linkage which is usually designed to allow the secondary throttle plates to begin opening once the primary throttle plates have rotated open about 40 degrees. Special Holley kits are also available which will allow the conversion to 1:1 linkage (primary and secondary throttle plates opening simultaneously) for special racing applications.

The opening rate of a vacuum secondary system is controlled by the diaphragm spring located in the vacuum secondary diaphragm housing. A "lighter" spring will allow the secondary throttle plates to open more quickly. A spring assortment kit, Holley P/N 20-13, is available to help you "tailor" the secondary opening rate to your application. A "quick change" kit Holley P/N 20-59, is also available for fast and easy access to the spring. It consists of a two-piece secondary diaphragm housing cover which, after its installed, can easily cut in half the time required to change the secondary spring.

**DO NOT** put a screw in the linkage of a vacuum secondary carburetor to mechanically "force" open the secondary throttle plates. Normally there is an accelerator pump on the secondary side of a mechanical secondary carburetor. The purpose of the secondary pump is to inject additional fuel to "cover" the transition time up to the point when the secondary main system starts to flow. Without this secondary pump shot the engine will go to an instant lean condition. Therefore, forcing the secondaries to open prematurely will hinder performance and may cause an engine backfire. The screw could also create a bind and cause the throttle to stick open.

### Vacuum Operated Secondary System.

